

ACmB3(4) Centrifugal cast iron pump

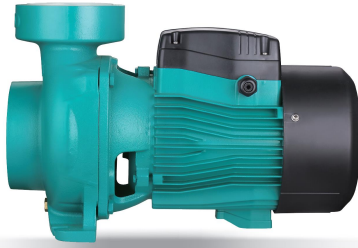

Application

- Transfer of clear water or other liquids chemically and physically comparable to water
- Suitable for industrial use and water supply, overpressure for fire system, garden irrigation, air conditioning system, circulation and overpressure, etc ...

Pompe

- Special anti-rust treatment (cataphoresis) for the cast iron pump body and the lantern
- AISI 304 stainless steel shaft
- Maximum liquid temperature: +40°C
- Maximum suction height: 8 m

Moteur

- Integrated thermal protection for single-phase motors
- Insulation class: F
- Protection class: IPX4
- Maximum ambient temperature: +40°C

Identification codes

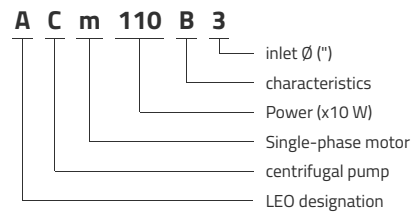

Technical data

MODEL	kW	Q (m ³ /h)	0	12	18	24	30	36	42	48	54	60	66	71
		Q (l/min)	0	200	300	400	500	600	700	800	900	1000	1100	1183
ACm110B3	1.1	12.5	12.5	12.1	11.5	10.5	9.5	8.4	7.1	5.5				
AC110B3	1.1	12.5	12.5	12.1	11.5	10.5	9.5	8.4	7.1	5.5				
ACm110B4	1.1	12.5	12.5	12.1	11.5	10.5	9.5	8.4	7.1	5.5				
AC110B4	1.1	12.5	12.5	12.1	11.5	10.5	9.5	8.4	7.1	5.5				
ACm150B3	1.5	14.5	14.3	14	13.5	12.8	12	11.2	9.9	8.4	6			
AC150B3	1.5	14.5	14.3	14	13.5	12.8	12	11.2	9.9	8.4	6			
ACm150B4	1.5	14.5	14.3	14	13.5	12.8	12	11.2	9.9	8.4	6			
AC150B4	1.5	14.5	14.3	14	13.5	12.8	12	11.2	9.9	8.4	6			
ACm220B3	2.2	17.5	17.3	17.1	16.5	16	15.2	14.2	13.2	11.7	10	7.2		
AC220B3	2.2	17.5	17.3	17.1	16.5	16	15.2	14.2	13.2	11.7	10	7.2		
ACm220B4	2.2	17.5	17.3	17.1	16.5	16	15.2	14.2	13.2	11.7	10	7.2		
AC220B4	2.2	17.5	17.3	17.1	16.5	16	15.2	14.2	13.2	11.7	10	7.2		
ACm300B3	3	20	19.8	19.6	19.5	19	18.3	17.5	16.2	14.6	13	11.5	10	
AC300B3	3	20	19.8	19.6	19.5	19	18.3	17.5	16.2	14.6	13	11.5	10	
ACm300B4	3	20	19.8	19.6	19.5	19	18.3	17.5	16.2	14.6	13	11.5	10	
AC300B4	3	20	19.8	19.6	19.5	19	18.3	17.5	16.2	14.6	13	11.5	10	

Dimensions

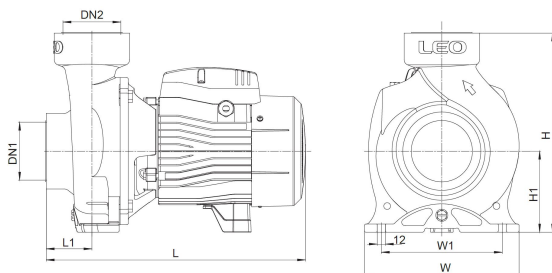

MODEL	DN1	DN2	L	W	H	L1	W1	H1
ACm110B3	3	3	386	230	295	68	180	120
AC110B3	3	3	386	230	295	68	180	120
ACm110B4	4	4	393	230	295	75	180	120
AC110B4	4	4	393	230	295	75	180	120
ACm150B3	3	3	386	230	295	68	180	120
AC150B3	3	3	386	230	295	68	180	120
ACm150B4	4	4	393	230	295	75	180	120
AC150B4	4	4	393	230	295	75	180	120
ACm220B3	3	3	453	230	295	68	180	120
AC220B3	3	3	453	230	295	68	180	120
ACm220B4	4	4	460	230	295	75	180	120
AC220B4	4	4	460	230	295	75	180	120
ACm300B3	3	3	453	230	295	68	180	120
AC300B3	3	3	453	230	295	68	180	120
ACm300B4	4	4	460	230	295	75	180	120
AC300B4	4	4	460	230	295	75	180	120

Hydraulic performance

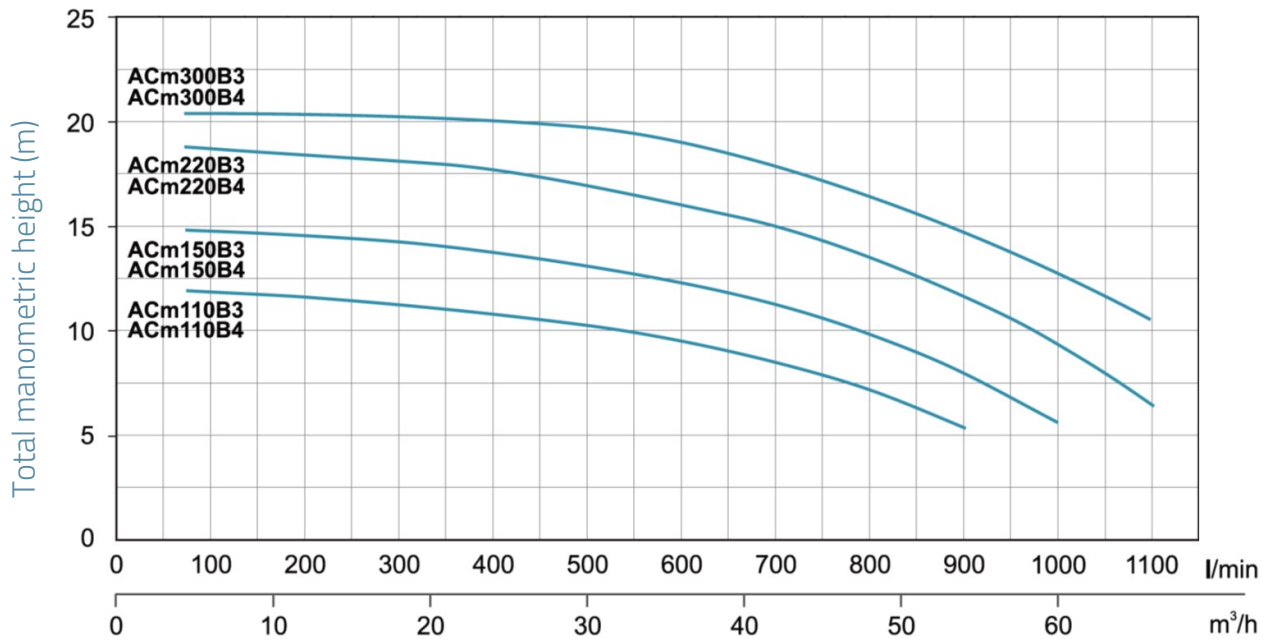

Exploded view

No.	Type	Materials
1	Filling plug	brass HPb59-1
2	Pump body	cast iron HT200
3	Impeller	brass
4	O-ring	nitrile rubber (NBR)
5	Mechanical seal	carbon / ceramic
6	Pump bottom	cast iron HT200
7	Oil seal	
8	Lantern	cast iron HT200
9	Bearing	
10	Rotor	
11	Terminal board	polycarbonate
12	Capacitor	
13	Electric box cover	ABS
14	Stator	
15	Rear cover	cast aluminum ZL102
16	Fan	polypropylene
17	Fan cover	polypropylene

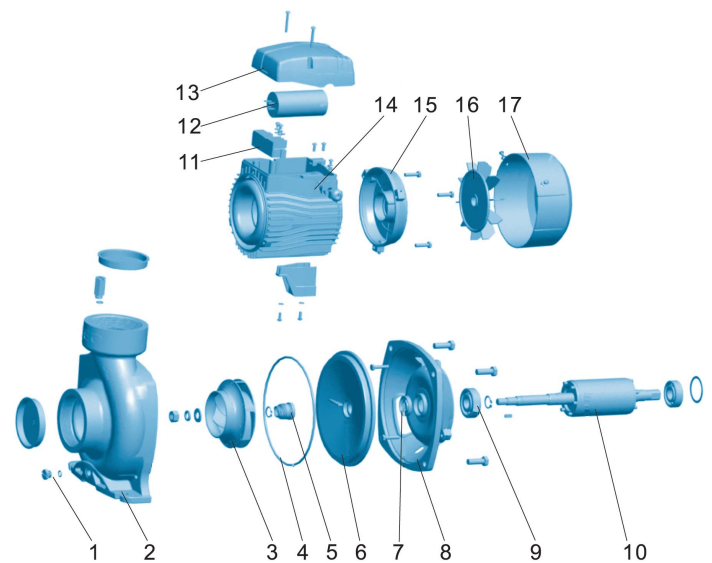

Packaging

MODEL	Weight (kg)	Length L (mm)	Width W (mm)	Height H (mm)
ACm110B3	26.3	433	255	332
AC110B3	26.3	433	255	332
ACm110B4	29.5	433	255	332
AC110B4	29.5	433	255	332
ACm150B3	27.2	433	255	332
AC150B3	27.2	433	255	332
ACm150B4	30.4	433	255	332
AC150B4	30.4	433	255	332
ACm220B3	34.8	522	288	331
AC220B3	34.8	522	288	331
ACm220B4	38	522	288	331
AC220B4	38	522	288	331
ACm300B3	37.3	522	288	331
AC300B3	37.3	522	288	331
ACm300B4	40.5	522	288	331
AC300B4	40.5	522	288	331

